

evolve®



USER MANUAL

Performance Road Frameset



Contents

1. INTRODUCTION	1
1.1. Warranty	1
2. GENERAL INFORMATION	2
2.1. Intended use	2
2.2. Structural weight limits	2
3. GEOMETRY	3
4. SPECIFICATIONS	4
4.1. evolve CIMA components	5
4.2. Tools required	10
4.3. Components compatibility	10
5. GENERAL NOTES ABOUT ASSEMBLY	11
5.1. Seatpost	12
5.1.1. Saddle	12
5.1.2. Seatpost wedge	13
5.1.3. Seatpost insertion	14
5.2. Cable routing	16
5.2.1. Brakes	17
5.2.2. Di2 Batteries	18
5.2.3. Shifting	19
5.3. Bottom bracket	22
5.4. Headset and fork assembly	23
5.5. Spacers, stems and handlebars	25
5.5.1. Kreuza Apex one-piece handlebar	25
5.5.2. Kreuza Apex one-piece handlebar accessory mount	28
5.6. Rear derailleur hanger	28
5.7. Final steps	29
6. GENERAL NOTES ABOUT MAINTENANCE	30

1. INTRODUCTION

THIS USER MANUAL CONTAINS IMPORTANT INFORMATION. PLEASE READ IT CAREFULLY AND STORE IN A CONVENIENT LOCATION.

This user manual is specific to your evolve CIMA bicycle. It contains important safety, performance, and technical information, which you should read before your first ride and keep for reference.

Make sure that your Authorized evolve Retailer has given you all the manufacturers' literature that was included with your bicycle or accessories. If there is a difference between the instructions in this manual and the information provided by a component manufacturer, please refer to your Authorized evolve Retailer or evolve official customer service.

Other language versions of this manual are available for download at [evolvebicycles.com](https://www.evolvebicycles.com). For questions about the bicycles, you can contact your Authorized evolve Retailer or evolve official customer service.

1.1. Warranty

Please refer to the written warranty provisions provided with your bicycle, or visit <https://www.evolvebicycles.com/warranty-policy/> to download the latest version. A copy is also available at your Authorized evolve Retailer.

When reading this user manual, you will note various important symbols and warnings, which are explained below:



WARNING! The combination of this symbol and word indicates a potentially hazardous situation that, if not avoided, could result in serious injury or death.



CAUTION: This safety alert symbol indicates a potentially hazardous situation that, if not avoided, may result in minor or moderate injury, or is an alert against unsafe practices.



NOTE: Indicates a situation that, if not avoided, may result in serious damage to the bicycle or void the warranty.



This symbol alerts the reader to information that is particularly important.



This symbol means that high-quality grease should be applied as illustrated.



This symbol means that high-quality carbon fiber anti-slip agent should be applied as illustrated.



This symbol indicates that LOCTITE 242 should be applied as illustrated.



Tech tips are useful tips and tricks regarding installation and use.

2. GENERAL INFORMATION

2.1. Intended use

The intended use of the evolve CIMA is for “Good Road Conditions” (ASTM CONDITION 1), and it has only been tested under these conditions: that is, this type of bicycle / component is only suitable for use on asphalt or tiled roads, where the wheels maintain continuous contact with the ground.



High-performance road bicycle testing standards are based on "good road conditions" where the tires do not lose contact with the ground.

Detailed information can be found in ASTM F2043

Intended to be ridden on paved roads only. Not intended for off-road, cyclo-cross, or touring with racks or panniers. Trade off: material use is optimized to reduce bike weight while delivering specific performance.

You must understand that

- (1) these types of bicycles are intended to give an aggressive racer or competitive cyclist a performance advantage over a relatively short product life.
- (2) a less aggressive rider will enjoy longer frame life.
- (3) you are choosing light weight (shorter frame life) over more frame weight and a longer frame life.
- (4) you are choosing light weight over more dent resistant or rugged frames that weigh more. All frames that are very light need frequent inspection. These frames are likely to be damaged or broken in a crash. They are not designed to handle harsh conditions or to serve as durable load carriers.

2.2. Structural weight limits

MODELS	CARGO		STRUCTURAL WEIGHT
	FRONT	REAR	
CIMA (ALL SIZES)	0 KG / 0 LB	0 KG / 0 LB	109 KG / 240 LB

Structural weight limit: The maximum total weight (rider and cargo) a bicycle is designed and tested to support structurally.

Cargo weight limit: The maximum cargo weight a bicycle has been designed and tested to support structurally.

3. GEOMETRY

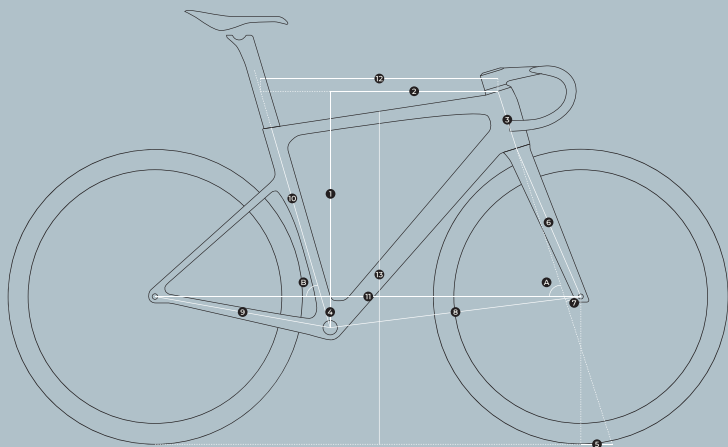

#evolve® CIMA

CIMA, inspired by mountain peaks, this frame captures the perfect blend of lightness and rigidity, ready to accompany you on journeys to the heart of nature. In tribute to the Giro d'Italia, reach every CIMA Coppi in your life and conquer your greatest challenges. Ride with evolve and embrace more time in nature—may its energy be with you always.

	XS	S	M	ML	L	XL
Height/cm	<163	161-170	168-177	175-184	182-192	>190
1.Stack/mm	506	528	544	562	580	608
2.Reach/mm	371	378	384	390	397	406
3.Head Tube Length/mm	103	122	138	153	173	203
A.Head Tube Angle	71.1°	72.2°	73°	73.8°	73.8°	73.8°
4.BB Drop/mm	74	74	72	72	70	70
5.Trail/mm	70	63	58	57	57	57
6.Fork Length Full/mm	372	372	372	372	372	372
7.Fork Rake/Offset/mm	44	44	44	40.2	40.2	40.2
8.Front Center/mm	571	573	579	579	591	608
9.Rear Center/mm	410	410	410	410	410	410
10.Seat Tube Length/mm	443	465	481	499	517	540
B.Seat Tube Angle	75°	75°	74°	74°	73.5°	73.5°
11.Wheelbase/mm	969	973	978	978	991	1008
12.Top Tube Length/mm	507	519	540	551	569	586
13.Standover Height/mm	727	749	767	785	805	829

*The sizes listed are for reference only and represent common cases, as limb proportions vary among riders of the same height. To find your ideal fit, consult our customer service with details of your previous bike brand and size for personalized advice.

4. SPECIFICATIONS

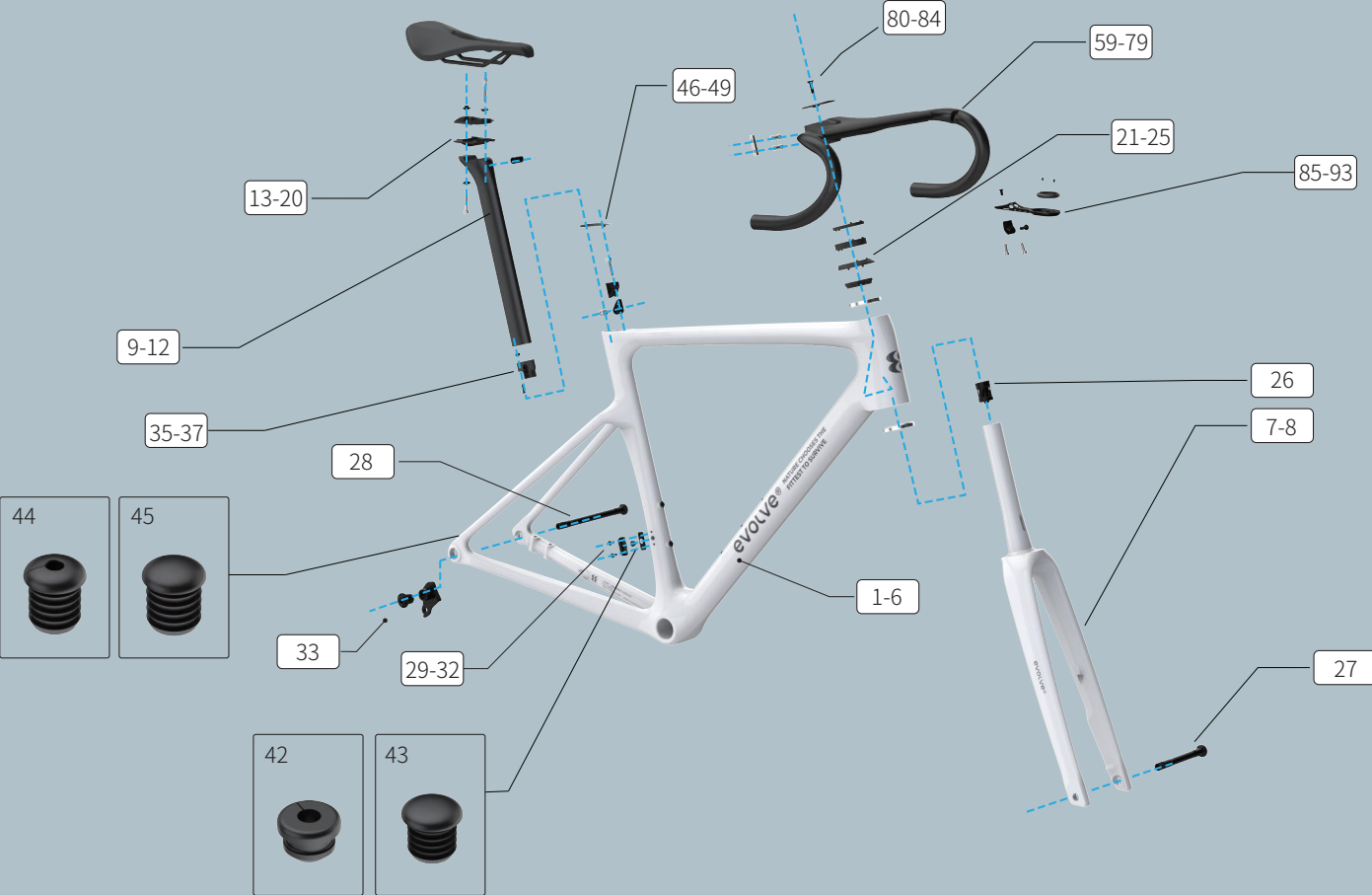

4.1. evolve CIMA Components

ITEMS	DESCRIPTION	PARTS	TOOL SIZE	TORQUE		
				Nm	in-lbf	
1	Frame	XS (Stack:506)	CI506-221001-00	-	-	-
2		S (Stack:528)	CI528-221001-00	-	-	-
3		M (Stack:544)	CI544-221001-00	-	-	-
4		ML (Stack:562)	CI562-221001-00	-	-	-
5		L (Stack:580)	CI580-221001-00	-	-	-
6		XL (Stack:608)	CI608-221001-00	-	-	-
7	Fork	Offset 44.0mm (XS \ S \ M)	CI544-211001-00	-	-	-
8		Offset 40.2mm (ML \ L \ XL)	CI562-211001-00	-	-	-
9	**Seatpost	Length:310mm / Offset 10 mm (XS \ S)	CI544-241001-00	-	-	-
10		Length:380mm / Offset 10 mm (M \ ML \ L \ XL)	CI544-241002-00	-	-	-
11		Length:310mm / Offset -5 mm (XS \ S)	CI544-241003-00	-	-	-
12		Length:380mm / Offset -5 mm (M \ ML \ L \ XL)	CI544-241004-00	-	-	-
13	Seatpost accessories	M6×36 front bolt *1	CI544-242007-00	4 mm hex	-	-
14		M5×28 rear bolt *1	CI544-242008-00	4 mm hex	6	53.1
15		Upper clamp	CI544-242001-00	-	-	-
16		Lower clamp	CI544-242002-00	-	-	-
17		Barrel Nut	CI544-242003-00	-	-	-
18		Rear nut	CI544-242005-00	-	-	-
19		Front bolt washer	CI544-242004-00	-	-	-
20		Rear bolt washer	CI544-242006-00	-	-	-
21	Headset accessories	Headset compression ring	CI544-222004-00	-	-	-
22		Headset spacer (5mm) *2	CI544-222005-00	-	-	-
23		Headset spacer (10mm) *3	CI544-222006-00	-	-	-
24		Headset cover (8mm)	CI544-222003-00	-	-	-
25		Upper and lower headset bearing	CI544-222001-00	-	-	-
26		Expansion hanging core	CI544-222002-00	6 mm hex	8	70.8
27	Axles	Front thru-axle	CI544-212002-00	6 mm hex	10	88.5
28		Rear thru-axle	CI544-222009-00	6 mm hex	10	88.5

4.1. evolve CIMA Components

ITEMS	DESCRIPTION	PARTS	TOOL SIZE	TORQUE			
				Nm	in-lbf		
29	Front derailleur hanger	Front derailleur cover	CI544-222021-00	-	-	-	
30		Front derailleur hanger -2X	CI544-222018-00	-	-	-	
31		***Front derailleur hanger -1x	CI544-222031-00	-	-	-	
32		M4x12 mounting bolt *2	FB-CL-M4*12-CD	2.5 mm hex	3	26.6	
33	Rear derailleur hanger	UDH derailleur hanger	CI544-222028-00	8 mm hex	25	221.3	
34		*** UDH direct mount derailleur hanger	CI544-222029-00	8 mm hex	25	221.3	
35	Di2 Battery mounting accessories	Di2 Battery mounting bracket	CI544-222032-00	-	-	-	
36		M4x15 bolt *1	FB-CL-M4*15-CD	2.5 mm hex	1.5	13.3	
37		M4 nut *1	CI544-222034-00	-	-	-	
38	Water bottle cage accessories	***Aerodynamic bottle cage	CI544-222012-00	-	-	-	
39		***Aerodynamic bottle	CI544-222013-00	-	-	-	
40		M5x9 water bottle cage mounting bolt *5	CI544-222011-00	4 mm hex	3	26.6	
41	Rubber plug	Seatpost waterproof rubber wedge cover	CI544-242009-00	-	-	-	
42		Front derailleur rubber plug	CI544-222016-00	-	-	-	
43		Front derailleur rubber plug	CI544-222017-00	-	-	-	
44		Rear derailleur rubber plug	CI544-222026-00	-	-	-	
45		Rear derailleur rubber plug	CI544-222027-00	-	-	-	
46	Other frame accessories	Seat post clamp	M5x27 seatpost clamp mounting bolt *1	CI544-232040-00	5 mm hex	7	62.0
47			Seatpost clamp nut	CI544-222024-00	-	-	-
48			Seatpost clamp upper wedge	CI544-222022-00	-	-	-
49			Seatpost clamp lower wedge	CI544-222023-00	-	-	-
50		***Seatpost number plate holder	CI544-242012-00	-	-	-	
51		***Seatpost radar holder	CI544-242011-00	-	-	-	
52		***Fork timing chip holder	CI544-212003-00	-	-	-	
53		Sponge sleeve	CI544-420001-00	-	-	-	
54	***Fixing bolts for flat mount disc brake calipers	***M5x14 front caliper fixing bolt*2	CI544-222035-00	T25 torx	6	53.1	
55		***M5x33,6 rear caliper fixing bolt*1-SHIMANO	CI544-222036-00	T25 torx	6	53.1	
56							

4.1. evolve CIMA Components

ITEMS	DESCRIPTION	PARTS	TOOL SIZE	TORQUE		
				Nm	in-lbf	
57		**M5×38.2 rear caliper fixing bolt *1-SHIMANO	CI544-222037-00	T25 torx	6	53.1
58		**M5×31.9 rear caliper fixing bolt *2-SRAM	CI544-222038-00	T25 torx	6	53.1
59	**KREUZA Apex one-piece handlebar	360mm x 80mm	KR608-231001-00	-	-	-
60		360mm x 90mm	KR609-231001-00	-	-	-
61		360mm x 100mm	KR610-231001-00	-	-	-
62		360mm x 110mm	KR611-231001-00	-	-	-
63		360mm x 120mm	KR612-231001-00	-	-	-
64		360mm x 130mm	KR613-231001-00	-	-	-
65		360mm x 140mm	KR614-231001-00	-	-	-
66		380mm x 80mm	KR808-231001-00	-	-	-
67		380mm x 90mm	KR809-231001-00	-	-	-
68		380mm x 100mm	KR810-231001-00	-	-	-
69		380mm x 110mm	KR811-231001-00	-	-	-
70		380mm x 120mm	KR812-231001-00	-	-	-
71		380mm x 130mm	KR813-231001-00	-	-	-
72		380mm x 140mm	KR814-231001-00	-	-	-
73		400mm x 80mm	KR008-231001-00	-	-	-
74		400mm x 90mm	KR009-231001-00	-	-	-
75		400mm x 100mm	KR010-231001-00	-	-	-
76		400mm x 110mm	KR011-231001-00	-	-	-
77		400mm x 120mm	KR012-231001-00	-	-	-
78		400mm x 130mm	KR013-231001-00	-	-	-
79	400mm x 140mm	KR014-231001-00	-	-	-	
80	One-piece handlebar top cover	KR811-232001-00	-	-	-	
81	M6×20 top cover mounting bolt *1	AB-CL-M6*20-CD	4 mm hex	3	26.6	
82	Handlebar rubber plug	KR811-232003-00	-	-	-	
83	M5×17 stem mounting bolt *2	KR811-232004-00	4 mm hex	6	53.1	

4.1. evolve CIMA Components

ITEMS	DESCRIPTION	PARTS	TOOL SIZE	TORQUE			
				Nm	in-lbf		
84	One-piece handlebar	Stem nut	KR811-232005-00	-	-	-	
85	Computer mount	Aluminum alloy computer mount	KR811-233001-00	-	-	-	
86		M5×16 computer mounting bolt *2	TN-SL-M5*16-CN	3 mm hex	3	26.6	
87		Computer base	Bryton	KR811-233004-00	-	-	-
88			Wahoo	KR811-233005-00	-	-	-
89			Garmin	KR811-233006-00	-	-	-
90		M3×6 bolt *2	FB-CL-M3*6-CD	2 mm hex	1	8.9	
91		Camera / light holder	KR811-233008-00	-	-	-	
92		M5×10 camera / light holder mounting bolt *1	FB-CL-M5*10-CD	3 mm hex	3	26.6	
93		M5×14 camera / light holder bolt *1	FB-SL-M5*14-CD	3 mm hex	3	26.6	
94		Other handlebar accessories	KREUZA AIR handlebar tape	KR811-234001-00	-	-	-

The items with ** are accessories with optional specifications and do not need to be purchased separately.

The ones with *** are optional accessories and need to be purchased separately.

evolve Kreuzu One-piece Handlebar and its Standard Parts



The Kreuzu Apex one-piece handlebar have a maximum spacer /headset cover stack of 1 x headset cover, 3 x 10 mm spacers, and 2 x 5 mm spacers.

4.2 Tools required

TOOL	SIZE/SPEC
Torque wrench	0-30 Nm / 0-265.5 in-lbf
Hex bits	2mm,2.5mm,3mm,4mm,5mm,6mm,8mm
Cable / housing cutters	Tool for cutting cable, housing and hose to required lengths during assembly.
High-quality grease	AUTOL TOP 2000
Blue threadlocker	LOCTITE 242
High-quality carbon fiber anti-slip agent	Feel free to pick any well-known brand on the market.

4.3 Component compatibility

Components	Compatible Sizes
Upper headset bearing	40.5mm ID x 49.5mm OD x 6.5mm
Lower headset bearing	40.5mm ID x 49.5mm OD x 6.5mm
Front thru-axle	12mm x 100mm
Rear thru-axle	12mm x 142mm
Min / max chainring	46t - 33t / 58t - 46t
Min / max front rotor	140mm / 160mm
Min / max rear rotor	140mm / 160mm
Min / max tire	24mm x 700c / 32mm x 700c

 Many bolts have a blue threadlocker patch on the threads to help secure the bolt under torque. Repeated installation and removal of a bolt may reduce the effectiveness of the patch. However, it can be replaced with the application of a liquid blue threadlocker.

 The components as summarized in this manual are current as of the date this manual was written and is subject to change. evolve reserves the right to change the components at any time and without notice, including modifying, reducing, and / or adding features.

 Tire sizes vary significantly from brand to brand. ISO 4210-2: 2023 standards require a minimum of 4mm of clearance between the frame / fork and the tires.

 When choosing a wheel and tire combo, factor in enough clearance for the conditions, setup and wheel flex.

5. GENERAL NOTES ABOUT ASSEMBLY

This manual is not intended as a comprehensive assembly, use, service, repair or maintenance guide. Please see an Authorized evolve Retailer for all service, repairs, or maintenance.



WARNING! When assembling or transporting the bicycle, clamp the stand to the seat post and not the top tube of the frame. Clamping the top tube of the frame can cause damage to the frame that may or may not be visible, and you may lose control and fall.



WARNING! Due to the complexity of the evolve CIMA bicycle, proper assembly requires a high degree of mechanical expertise, skill, training and specialty tools. Before your first ride, make sure your components, such as brakes and drivetrain, are assembled and adjusted in accordance with the manufacturer's instructions and are functioning properly.



WARNING! Many components on the evolve CIMA are proprietary. Only use originally supplied components and hardware at all times. Use of other components or hardware will compromise the integrity and strength of the assembly. CIMA specific components should only be used on the evolve CIMA bicycles and not on other bicycles, even if they fit. Failure to follow this warning could result in serious injury or death.



WARNING! Never modify your frame or bicycle in any way. Do not sand, drill, file or remove parts from your bicycle. Do not install incompatible components or hardware. Failure to follow this warning may result in serious personal injury or death.

5.1. Seatpost

5.1.1. Saddle

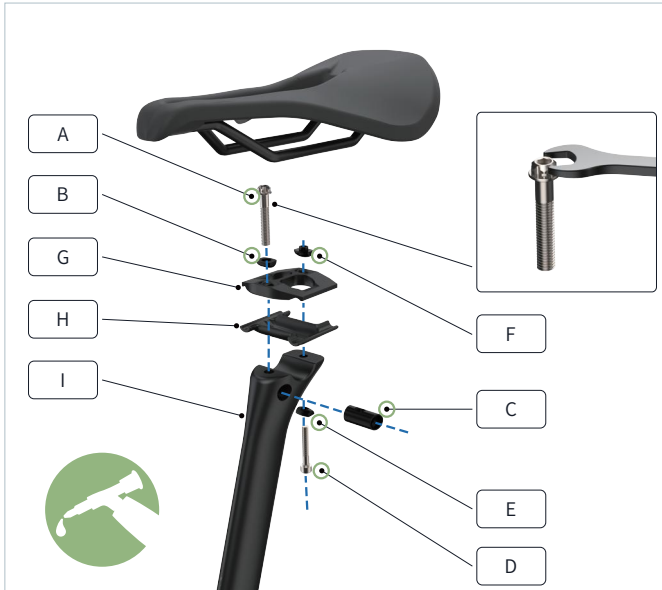

- Grease then install the M6 barrel nut (C) inside the seatpost (I).
- Install the lower cradle (H).
- Grease and assemble the M6 front bolt spacer (B), then install them in the upper cradle (G).

- Assemble the M5 rear bolt (D) through the M5 cradle washer (E), seatpost bolt hole, lower cradle (H), upper cradle (G), and loosely thread into the M5 nut (F).
- Adjust the saddle fore-aft position, then loosen or tighten bolt A to adjust the angle of the saddle.
- Using a torque wrench and 4 mm hex bit, torque bolt D to 6 Nm / 53.1 in-lbf, then check the saddle angle. If the angle still needs to be adjusted, loosen bolt D, loosen or tighten bolt A accordingly, then torque bolt D again. Repeat until the saddle is at the desired angle.

N Please attach the saddle to the seatpost before inserting the seatpost into the seat tube to prevent the barrel nut (C) from falling into the seat tube.

i If using a saddle without a central opening, bolt A can be adjusted by an 8 mm wrench.

5.1.2. Seatpost wedge

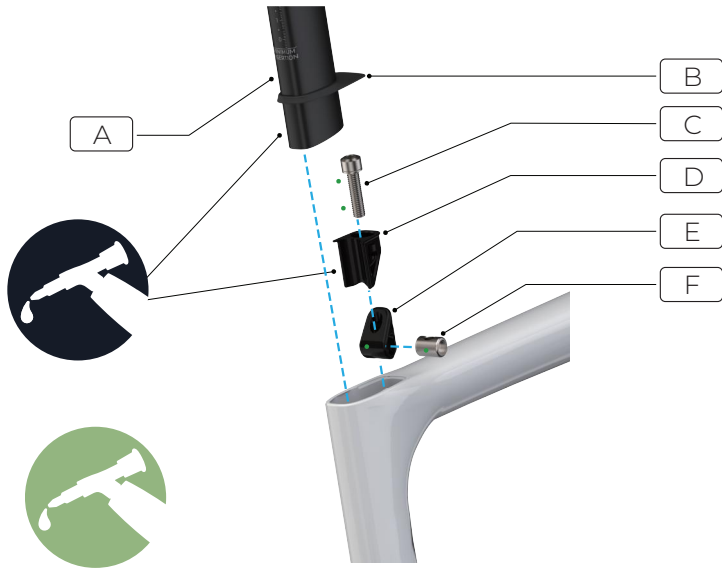

- Insert the seatpost into the seat tube, then insert the seatpost wedge assembly in the seat tube in front of the seatpost. Ensure the concave wedge surface is against the seatpost.
- Once the saddle height is determined, use a torque wrench and 5 mm hex bit to torque the seatpost wedge bolt (C) to 7 Nm / 62 in-lbf.



WARNING! Before tightening the seatpost wedge, it is important to make sure it's fully seated inside the seat tube in front of the seatpost.



NOTE: When inserting the seatpost, be careful not to pinch any Di2 cables.



NOTE: When removing the seatpost, loosen but do not remove the wedge bolt. Fully loosening the bolt and removing the seatpost could lead to the lower wedge and barrel nut falling into the seat tube.

Assemble the seatpost wedge

- Apply grease to the contact surfaces between the seatpost wedge parts C, D, E, F.
- Assemble the barrel nut (F) into the lower wedge (E). Thread the washer and bolt (C) through the upper wedge (D), then the lower wedge (E) and gently tighten the bolt.
- Slide the seatpost wedge cover (B) onto the seatpost (A), then apply carbon fiber anti-slip agent to the seatpost and concave wedge surface.
- If necessary, plug the Di2 front and rear derailleur wires into a connector on the Di2 battery using the Shimano connector tool.

5.1.3. Seatpost Insertion

Both the frame and seatpost have minimum insertion requirements. Plus, the frame has a maximum insertion requirement to prevent damage to the frame and seatpost.

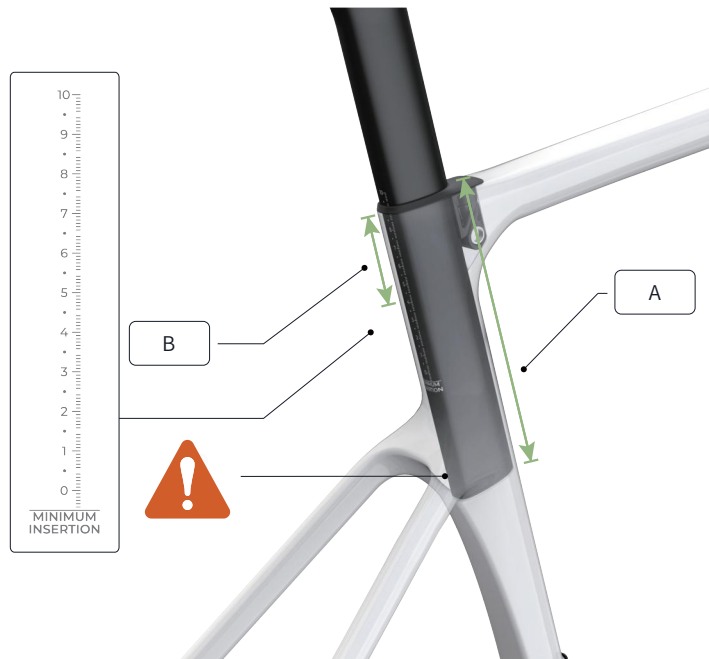

Minimum insertion

- The seatpost must be inserted exceeding minimum insertion mark, and must not beyond the maximum insertion required in the chart below to prevent damage to frame and seatpost (B). The minimum insertion depth required is 75mm.

Maximum insertion

- The seat tube contour changes part-way down and is designed to accommodate a specified maximum insertion depth (A) for each frame size. This contour change limits the insertion depth of the seatpost. Please refer to the table below.

Frame Size	XS	S	M	ML	L	XL
Maximum Insertion (mm)	129	150	161	173	191	215



WARNING! When inserting the seatpost, there should be sufficient space between the bottom end of the seatpost and the contour so as to not cause any structural damage to the frame.

- If the desired seat height cannot be achieved within the minimum and maximum insertion requirements, the seatpost should be replaced for a shorter or longer one.
- Once the saddle height is determined, use a torque wrench and a 5 mm hex bit, to torque the seatpost wedge bolt to 7 Nm / 62 in-lbf.



The evolve CIMA seatpost is available in two lengths (310 mm and 380 mm) and two setbacks (0 mm and 15 mm). If the 380 mm post is too long, we recommend using the 310 mm seatpost.



The fit between the seatpost and the seat tube must allow the seatpost to slide into the seat tube smoothly and without twisting, but not so loosely that there's excessive side-to-side play / wiggle. Any fit and / or torque issues should be inspected by an Authorized evolve Retailer. If the seatpost does not fit properly or moves in the frame even though it is torqued to spec, you should have it inspected by an Authorized evolve Retailer.



Do not apply grease to the carbon contact surfaces between the seatpost and the seat tube. Grease reduces friction, which is critical to proper seatpost grip. evolve recommends the application of carbon fiber anti-slip agent, which can increase friction between carbon surfaces. Please visit a evolve Authorized Retailer for additional information.



WARNING! Failure to follow the seatpost and frame insertion requirements may result in damage to the frame and / or seatpost, which could cause you to lose control and fall. If the seatpost is cut short, the min / max mark on the seatpost may no longer be accurate. Before cutting the seatpost, note the min / max depth required by the manufacturer.

5.2.1. Brakes

Rear brake (red hose)

Run the rear brake hose in through the chainstay ICR port (1), through the chainstay, over the bottom bracket shell, and up the down tube exiting through the upper head tube hole.

Slide a foam sleeve (2) over the rear brake hose, through the upper head tube hole, and into the down tube. The foam sleeve starts 20 mm below the head tube / down tube kink and ends 40 mm behind the bottom bracket shell.



See section 5.5. *Spacers, stem and handlebars* as you'll need to route brake hoses through the headset cover, headset spacers, and handlebar before you can finish installing the rear and front brakes according to the manufacturer's instructions.

Install the brake caliper on the chainstay and complete the rear brake installation according to the brake manufacturer's instructions.

Front brake (blue hose)

Run the front brake hose in through port (3) and guide it up the fork leg until it exits the port (4) at the front of the steerer tube. Use a pick to help guide the hose out of the port.

Install the caliper on the fork leg according to the brake manufacturer's instructions.

Once the brake is mounted to the fork, secure the brake hose to the steerer tube with a section of strong adhesive tape (5).

Install the fork according to the steps outlined in section 5.4. *Headset and fork assembly* and complete the front brake installation according to the brake manufacturer's instructions.

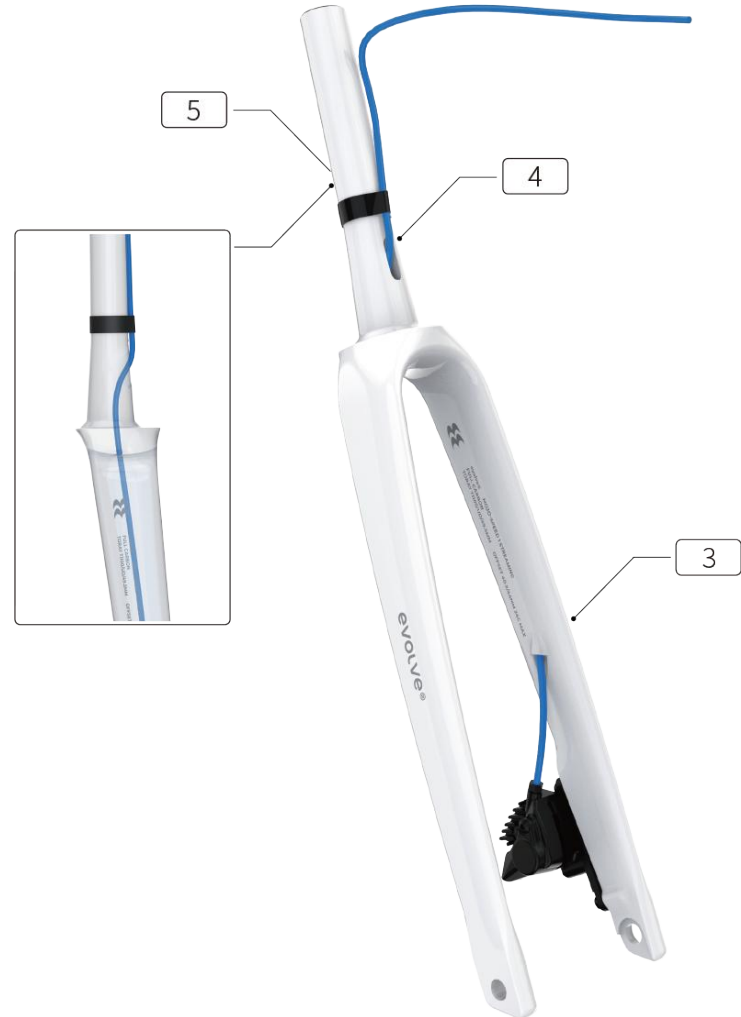

5.2.2. Di2 Battery (Di2 equipped bicycles)

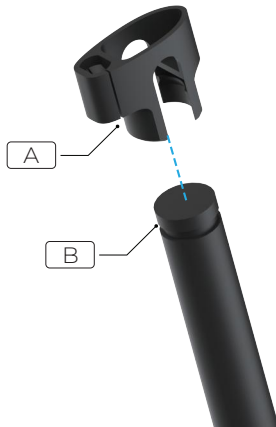

The Di2 battery is held in place in the seatpost using a mounting clip and should be installed before inserting the seatpost into the seat tube.

Assembly

- Place the mounting clip (A) around the battery (B) making sure that the ridge on the inside of the clip fits in the corresponding slot on the battery.
- Align the cable tie (C) with the groove on the outside of the mounting bracket. Tighten the cable tie to securely fix the battery to the mounting bracket, preventing any dislocation or shifting. Cut off any excess length of the cable tie.
- Align the bolts (D) and nuts (E) with the holes on the mounting bracket. Lock them slightly. Insert the assembly into the seatpost (F) and tighten the bolts (D) until the assembly is stable and does not shake.

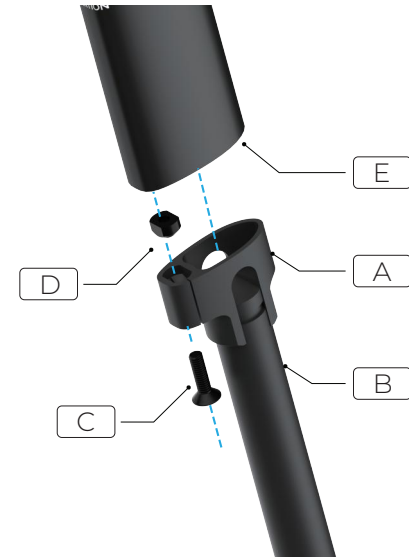

Disassembly

- Loosen the bolts (D) and gently pull the assembly out of the seat post (F).
- Cut off the cable tie (C) and gently pry the battery (B) from the bulge on the inside of the mounting bracket (A) to remove the battery.



NOTE: Do not over-tighten the bolt (D). Over-tightening may cause the bottom of the seatpost (F) to expand, making it difficult to insert the seatpost properly.

5.2.3. Shifting



Your bicycle is set up with electronic shifting and is not compatible with mechanical shifting.

SRAM

SRAM Wireless systems do not require internal cable routing. When installing SRAM components onto the bicycle, ensure all derailleur ports are sealed with the appropriate grommet.

Shimano Di2

The Shimano Di2 system is internally routed in the evolve CIMA frame.

Di2 FRAME WIRING LENGTHS		
LOCATION	QTY	LENGTH
Rear derailleur – battery	1	1200mm
Front derailleur – battery	1	600mm

Backing plate assembly

The front derailleur hanger is mounted by inserting bolts through the hanger and threading them into a backing plate. This backing plate must be held in position to install the bolts. To hold the backing plate in position, follow the steps below:

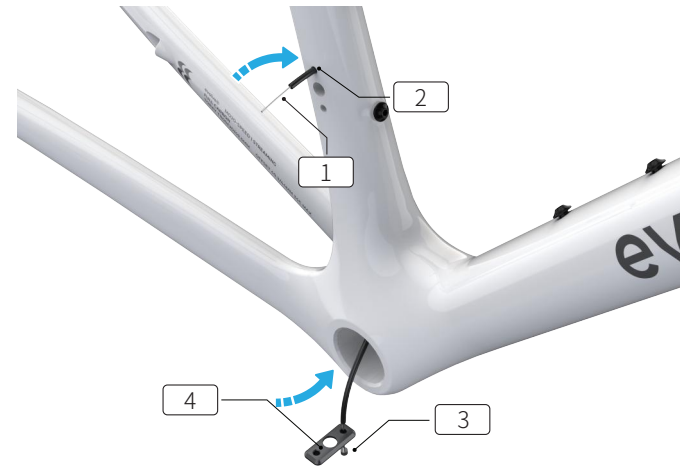

- Insert a shifter cable housing (1) through the upper bolt hole (2) and out of the bottom bracket shell.
- Insert a shifter cable (3) through the backside of the backing plate (4), then guide the shifter cable up the shifter housing until the cable exits the upper bolt hole (2).

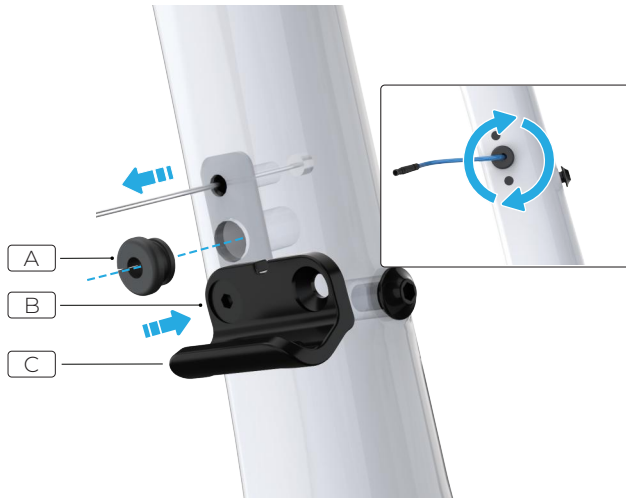

- Pull on the cable exiting the bolt hole (2) while guiding the backing plate up into the seat tube until it rests against the inside of the seat tube.
- Align the screw holes beneath the front derailleur hanger (C) with the corresponding bolt holes on the seat tube. Partially tighten the bolts (B) to ensure that the opening in the center of the backing plate aligns with the corresponding opening on the seat tube.
- Thread a 600mm cable through the rubber plug (A) and the opening on the side of the seat tube, then guide it out through the top of the seat tube.
- Insert the rubber plug (A) through the side opening of the seat tube and push it into the backing plate, ensuring it is securely fixed in place with the backing plate.
- Remove the cable and housing by guiding it down the seat tube and out of the bottom bracket shell.

Di2 Front derailleur (Blue wire)

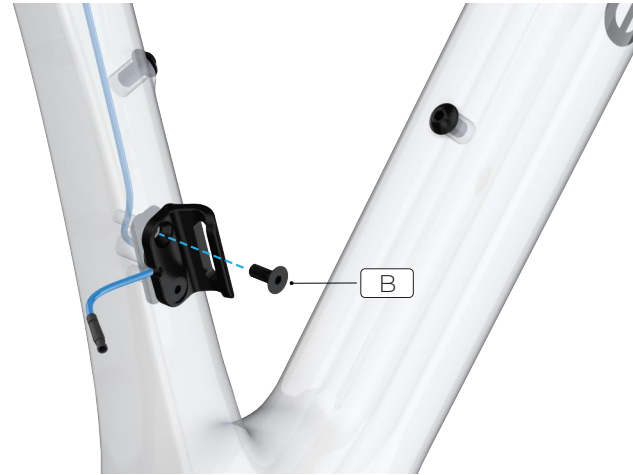

- Insert the upper mounting bolts (B) . Use a torque wrench and a 2.5 mm hex bit, tighten the front derailleur hanger bolts to 3Nm / 26.6 in-lbf.



NOTE: Do not pinch the Di2 cable when assembling the front derailleur hanger.



If you are using a 1x front chainring, then you should remove the front derailleur hanger components and install the supplied metal cover (D) (S201900002) over the front derailleur mounting points and ICR port.

Di2 Rear derailleur (Green wire)

- Route a 1200 mm long wire from the seatstay rear derailleur ICR port and out of the top of the seat tube.
- Install a Di2 grommet over the wire at the chainstay rear derailleur ICR port.

If using an 11 speed Di2 system, junction box is housed in the handlebar. Route the wires according to the manufacturer's instructions.

Di2 Battery

- Install the Di2 battery into the seat post mounting clip, then install the assembly into the bottom of the seatpost.
- Plug the front and rear derailleur cables into a connector on the Di2 battery using the Shimano connector tool.
- Insert the seatpost assembly into the seat tube and install it according to *section 5.1. Seatpost* of this User Manual.



NOTE: When inserting the seatpost, be careful not to pinch and damage the Di2 cables.

- Install the front and rear derailleurs, then complete the setup according to the manufacturer's instructions.

5.3. Bottom bracket

The evolve CIMA frames use a 68 mm standard BSA threaded design. Grease the threads, install, and torque according to the bottom bracket manufacturer's instructions.



Before installing the bottom bracket and crank, make sure all housings and wires are routed through the frame.



CAUTION: Do not face the bottom bracket shell! This can prevent proper installation of the crank. Your evolve frame does not require any bottom bracket shell pre-installation preparation, as all surfaces have been precisely machined to specific tolerances at the factory for proper interface with a compatible crankset. Please refer to the manufacturers instructions for crank and bottom bracket installation.

5.4. Headset and fork assembly

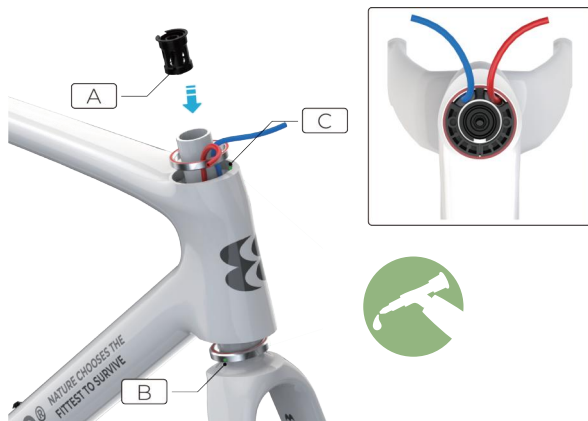

Preparing the fork

- Determine the rider's fit (*section 3.Geometry*) and the resulting steerer tube length.
- Cut the steerer tube to the desired height. This can be done with or without the brake hoses installed. Don't cut the steerer tube more than 5mm below the top of the stem!

N NOTE: When inserting the seatpost, be careful not to pinch and damage the Di2 cables.

- Using a torque wrench and 6 mm hex bit, torque the expander bolt to 8 Nm / 70.8 in-lbf.

- Ensure the front brake hose is located against the steerer tube with strong adhesive tape before starting the headset installation.

i Installation and replacement of the expander plug can be performed with the fork on the bicycle without uncoupling or re-routing the brake hoses.

! WARNING! Once the rider's fit has been determined, the steerer tube should be cut 3 mm below the top of the stem. For actual riding, the stem requires full support from the expander plug inside the fork to function safely and as intended.

N NOTE: The height of the stem of Kreuza one-piece handlebar is 35mm, and the required length of the steerer tube is 32mm. If you replace the stem with another model, you need to confirm whether the length of the steerer tube meets the usage requirements.

Install the headset bearings

- Grease then install the lower headset bearing (B) in the lower head tube cup, then run the steerer tube with front brake hose into the head tube. The rear brake hose should exit the top of the head tube alongside the steerer tube.
- Grease then install the upper headset bearing (C) down over the steerer tube and into the upper head tube cup with the brake hoses between the upper headset bearing and the steerer tube.

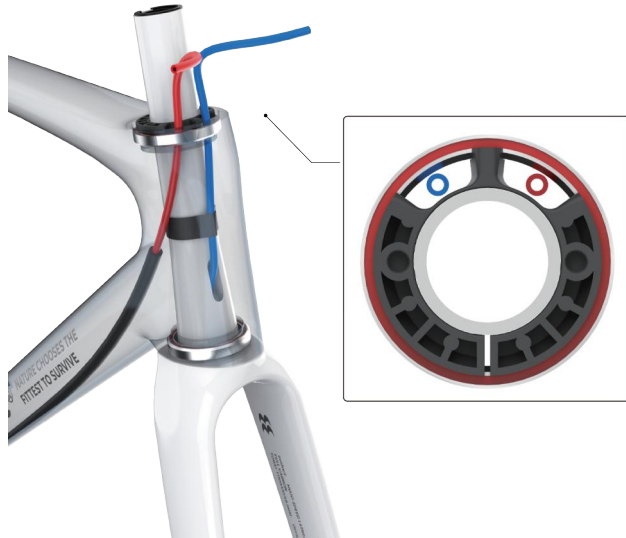

Install the compression ring

- Guide the brake hoses through the respective slots of the compression ring, install the compression ring on the steerer tube, then seat the ring in the upper bearing.
- With the fork facing forward and the hoses sticking up out of the frame, rotate the fork 90 degrees in the direction opposite the side the rear brake is routed. This allows the rear brake hose to wrap around the steerer tube as it rotates.
- With the fork rotated 90 degrees, gently pull the rear brake hose until it is taut in the frame, then push 20 mm of hose back down into the frame to allow for some stack adjustment and prevent binding when the handlebars are turned.



The brake hoses must always pass through the side slot of the compression ring that matches the relevant brake lever side. The brake hoses must not cross each other.

5.5. Spacers and handlebars

5.5.1. Kreuza one-piece handlebar

Install the headset cover and spacer stack

Guide the brake hoses through the respective holes of the headset cover, then guide them up through the front holes of the spacer stack as you slide the headset cover and spacers onto the steerer tube.



The spacers are split so they can be installed or removed to adjust stack height without removing the brake hoses. To do this, engage the clip, install the spacer on the steerer tube, then vertically slide the clip together.



Spacers require the use of the headset cover at all times. The headset cover has two pins that key into two holes in the compression ring. Make sure they are aligned and keyed in.

Install the brake hoses



Internally route the brake hoses into their respective handlebar sides until they exit the handlebar side ports.



From when they exit the steerer tube to when they enter the handlebar, the brake hoses must not cross each other. If the rear brake lever is on the right, then the rear brake hose exits the head tube on the right and remains on that side until it enters the right handlebar port.

Install the handlebar

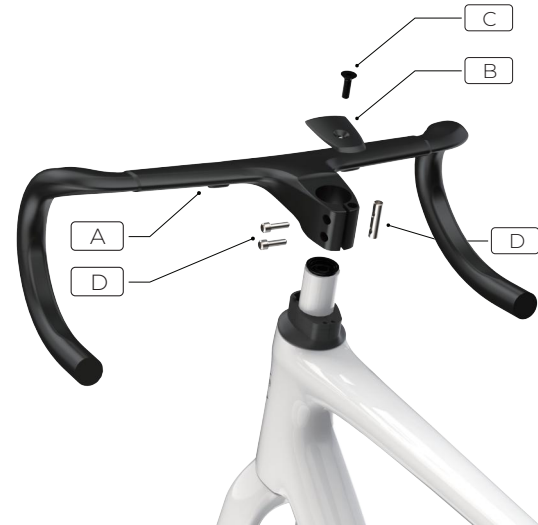

Install the Kreuzer Apex one-piece handlebar (A) on the steerer tube.

Place the stem faceplate (B). Use a torque wrench and 4 mm hex bit to tighten the bolts (C) to 3Nm / 26.5in-lbf until the headset is properly adjusted and there are no gaps or wraps in the headset assembly. Make sure it's centered.

Use a torque wrench and 4 mm hex bit to tighten the stem bolts (D) to 6Nm/53.1in-lbf.



Warning: To ensure the fork tube is securely locked and used safely, the distance between the top of the steerer tube and the top of the fork tube must be between 2mm and 5mm. The recommended distance is 3mm.

Complete the handlebar installation

Slide the brake / shift lever band clamps onto the handlebar, then install the brake / shift levers on the clamps.

Align the brake / shift levers and torque the clamp bolts to the manufacturer's specifications.



WARNING! Do not twist the band clamp to install it on the handlebar. This can result in damage to the carbon handlebar.

- Install the handlebar end caps.
- Wrap the handlebar tape around the handlebar.
- Finish the brake / shifter setup according to the manufacturer's instructions.



Before cutting the hoses, it can be helpful to push some excess hose into the frame. This allows for possible minor future fit adjustments.

With the bicycle on the ground, pull the front brake and rock the bicycle back and forth to ensure the headset is fully seated and there is no looseness.

5.5.2. KREUZA Apex one-piece handlebar accessories mount

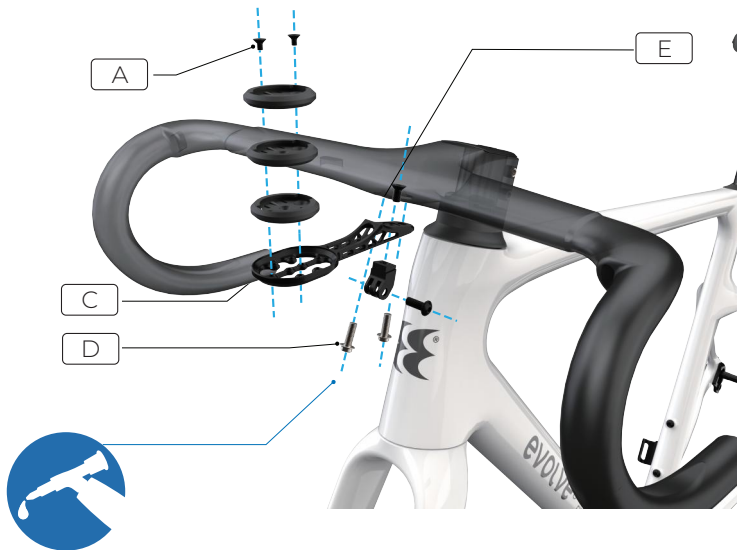

Apply Loctite 242 to the mounting bolt (A), and tighten A and F based on your need.

Apply Loctite 242 to the mounting bolt (D), then place the accessory mount (C) on the threaded installing point (E). Use a torque wrench and 3 mm hex bit to torque the bolt to 3Nm / 26.6in-lbf.

5.6. Rear derailleur hanger

The derailleur hanger is a replaceable part that connects the rear derailleur to the bicycle frame and is mounted directly at the rear dropout.

The derailleur hanger is designed to bend or break on impact in order to protect the frame and derailleur from damage.

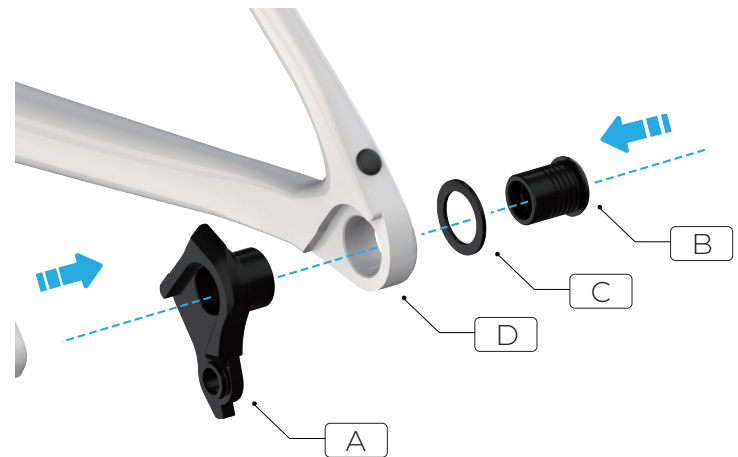

Install the derailleur hanger (A) so that it's seated in the dropout (D) and the bolt hole is aligned with the one in the frame.

Gently tighten the derailleur hanger bolt (B) and hanger washer (C) so that the derailleur hanger is held in place against the frame.

Apply proper amount of grease at the inner thread of the derailleur hanger (A).

Use a torque wrench and 8 mm hex bit, torque the derailleur hanger bolt (B) to 25 Nm / 221.27 in-lbf.



Follow the manufacturer instructions when mounting the universal derailleurs hanger to the frame.
SRAM -<https://www.sram.com/en/sram/models/ac-drhg-mtb-a1>

5.7. Final steps

Finish any remaining steps for installing the drivetrain and other components according to the component manufacturer's instructions. Check the fit, then double-check the torque specs for all bolts.

6. GENERAL NOTES ABOUT MAINTENANCE

The evolve CIMA is a high-performance bicycle. All regular maintenance, troubleshooting, repair, and parts replacement must be performed by an Authorized evolve Retailer. For general information regarding the maintenance of your bicycle, please refer to the Owner's Manual. In addition, routinely perform a mechanical safety check before each ride as described in the Owner's Manual. Great care should be taken not to damage the frame material. Damage may result in a loss of structural integrity, which may result in a catastrophic failure. This damage may or may not be visible during inspection. Before each ride, and after any crash, you should carefully inspect your bicycle for any gouging, scratches through the paint, chipping, bending, or any other signs of damage. Do not ride if your bicycle shows any of these signs. After any crash, and before you ride any further, take your bicycle to an Authorized evolve Retailer for a complete inspection. While riding, listen for any creaks as a creak can be a sign of a problem with one or more components. Periodically examine all surfaces in bright sunlight to check for any small hairline cracks or fatigue at stress points, such as welds, seams, holes, and points of contact with other parts. If you hear any creaks, see signs of excessive wear, discover any cracks, no matter how small, or any damage to the bicycle, immediately stop riding the bicycle and have it inspected by an Authorized evolve Retailer. Lifespan and the type and frequency of maintenance depends on many factors, such as use, rider weight, riding conditions, and / or impacts. Components may be subject to increased wear at different rates, depending on the component. Drivetrain and brake components are especially subject to wear. Periodically have an Authorized evolve Retailer inspect your bicycle and components for wear. Exposure to harsh elements, especially salty air (such as riding near the ocean or in the winter), can result in galvanic corrosion of components such as the crank spindle and bolts, which can accelerate wear and shorten the lifespan. Dirt can also accelerate

wear of surfaces and bearings. The surfaces of the bicycle should be cleaned before each ride. The bicycle should also be maintained regularly by an Authorized evolve Retailer, which means it should be cleaned, lubricated, and (partially) disassembled and inspected for signs of corrosion and / or cracks. If you notice any signs of corrosion or cracking on the frame or any component, the affected item must be replaced.

Regularly clean and lubricate the drivetrain according to the drivetrain manufacturer's instructions.

Do not use a high pressure water spray to wash your bicycle. Even water from a garden hose can penetrate seals and water may seep into components, such as cranks, or bearings, potentially causing damage. Use a clean, damp cloth and bicycle cleaning agents (where appropriate) for cleaning.

Do not expose the bicycle to prolonged direct sunlight or excessive heat, such as inside a car parked in the sun or near a heat source such as a radiator.



WARNING! Failure to follow the instructions in this section may result in damage to the components on your bicycle and will void your warranty, but, most importantly, may result in serious personal injury or death. If your bicycle exhibits any signs of damage, do not use it and immediately bring it to an Authorized evolve Retailer for inspection.



WARNING! Use a repair stand to support the bicycle during assembly or maintenance, and a bicycle rack for transportation. When placing the frame and / or bicycle in a repair stand, clamp the stand to the seatpost and not the frame. Clamping the frame can cause damage to the frame that may or may not be visible, and you may lose control and fall.

